

Naming conventions

for parts and documents in MAX IV

Sheet "what" should be updated whenever a new item is identified.

Then the sheet "Type" will be recreated.

Drafts by:

Jonny Ahlbäck/ Sara Thorin / Simon Leemann

ver4:	First released version in MAX IV document server	2010-04-26	Jonny
ver5a:	Updated version from the draft of 2010-05-21 New components introduced. New layout with components listed on sheet "What" in alphabetic order and documents and examples on sheet "Doc" Some components will be used in more than one sub-system (1, 3, I..) This means that the acronyms alone should define the type/version of object Example: DIL, DIP, DIM stand for different dipole models The sub system label defines where the component is used, regardless of to where it first was designed. Pictures on sheet "Main"	2010-06-08	Jonny
Ver6:	New components introduced. New names are marked with a gray background Deleted names are marked with red background and strikeout Sheets "Type" and "What" has the same sorted information Sheet Layout added	2010-06-29	Jonny
ver 7:	New components introduced. More examples and layout pictures added Table Main sorted after System and then Location	2010-07-09	Jonny
ver8:	New components introduced.	2010-08-16	Jonny

When new acronyms are introduced, they must be added to this convention file.

Send your proposals to Jonny A. or Martin J.

In some (CAD-)systems, the full stop (.) is a problem, thus the underscore (_) is proposed as an alternative in those systems

The placeholder "-" is used in systems where the number of characters must be constant.

cc: Bengt A; Claes L; Dionis K; Elsayed E; Erik W; Johan T; Jonas M; Jonny A; Krister L; Lars M; Lars-Johan L; Magnus B; Magnus S; Martin J; Sara T; Simon L; Åke A

Naming of components in the MAX IV systems

The name is composed by acronyms with sections Where_What_Sub_Information

The proposed names are shown in the following matrixes

indicates location position number

* indicates a "wild card" if the position is not used

Unused positions at the end in a group may be omitted if the divider "_" or "." is used

1 + 4 positions giving the Main system and location

5 positions saying what kind of unit with position in the location

5(?) positions corresponding to coil, thermo switch etc also for serial numbers or signal names

Acronyms depending on type of document, to be decided, see the BPM test example (A) on sheet "Doc"

Description	Where		What	sub	Information
	System	Location	What	sub	document or signal
1.5GeV ring	1 .				
3 GeV Achromat magnet section (# = 01-20)	3 . # # * *		* * * * *		
3 GeV Long straight (# = 01-20)	3 . # # L *		* * * * *		
3 GeV Achromat matching cell (# = 1-2)	3 . * * M #		* * * * *		
3 GeV Achromat short straight (# = 1-2)	3 . * * S #		* * * * *		
3 GeV Achromat unit cell (# = 1-5)	3 . * * U #		* * * * *		
3GeV ring	3 .				
Beam line in 1.5GeV	B . 1 # * *				
Beam line in 3GeV	B . 3 # # *				
Beam line for FEL	B . F # # *				
Beam line for SPF	B . S # # *				
Control system	C .				
Inj. Bunch compressor (# = 1&3)	I . B C # *		* * * * *		
Inj. Diagnostic section	I . D I A *		* * * * *		
Inj. Gun system	I . G * * *		* * * * *		
Inj. Gun diagnostic line	I . G D L *		* * * * *		
Inj. Gun for Rings	I . G R * *		* * * * *		
Inj. Gun for SPF	I . G S * *		* * * * *		
Inj. Intra sections (# = 00a-19b)	I . I # # #		* * * * *		
Inj. Linac sections (#=00a-19b)	I . L # # #		* * * * *		
Inj. Micro wave system (#=0-19)	I . M W # #		* * * * *		
Inj. Short Pulse Facility	I . S P # #		* * * * *		
Inj. Transfer to Ring 1.5GeV	I . T R 1 *		* * * * *		
Inj. Transfer to Ring 3GeV	I . T R 3 *		* * * * *		
Inj. Transfer to SPF	I . T S # *		* * * * *		
Injector	I .				
Laser	L .				
Power (mains) distribution system	P .				not inside the other systems
Structure (Building)	S .				
Water Cooling distribution system	W .				not inside the other systems

For components see the sheets What and Type

For examples see the sheets Layout and Doc

Accelerator principal layout

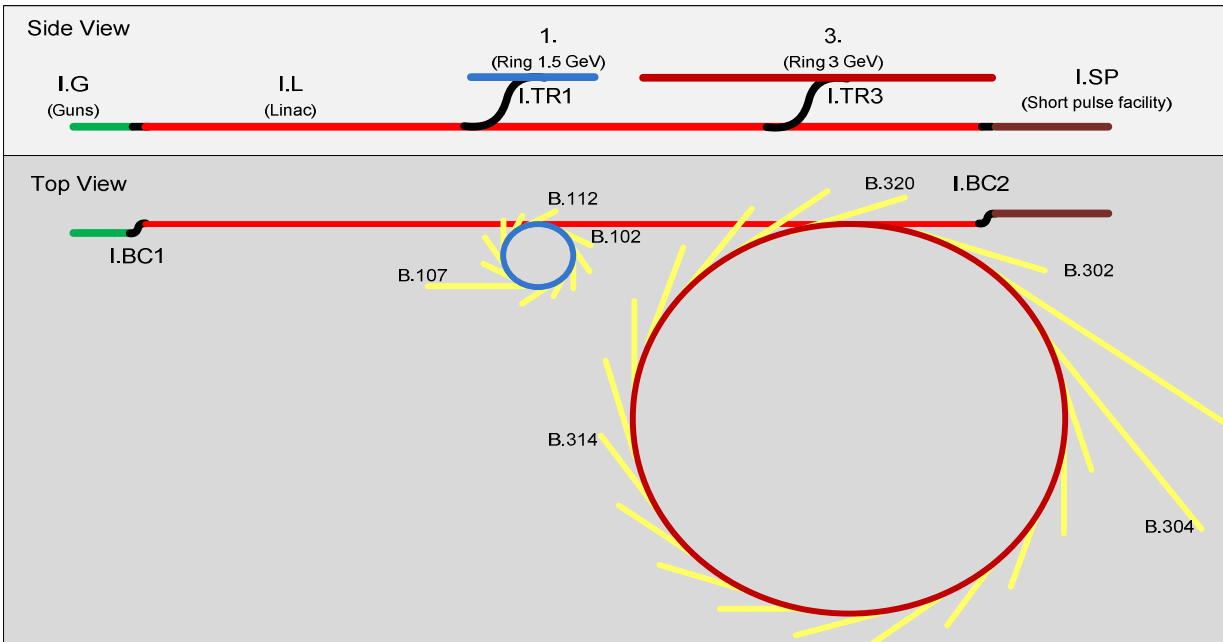

The ring numbering starts at the injection

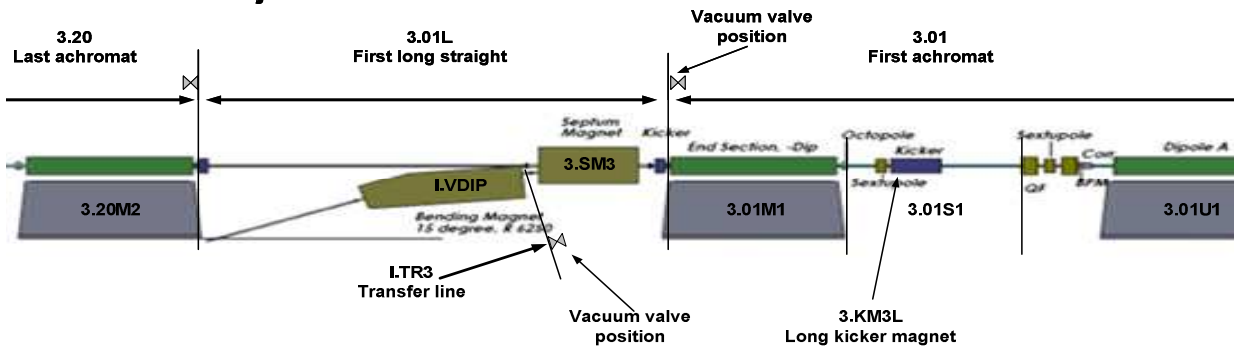

Example: Sections 3.01, 3.01L, 3.02, and 3.B02

The Gate valves are the limits between these sections

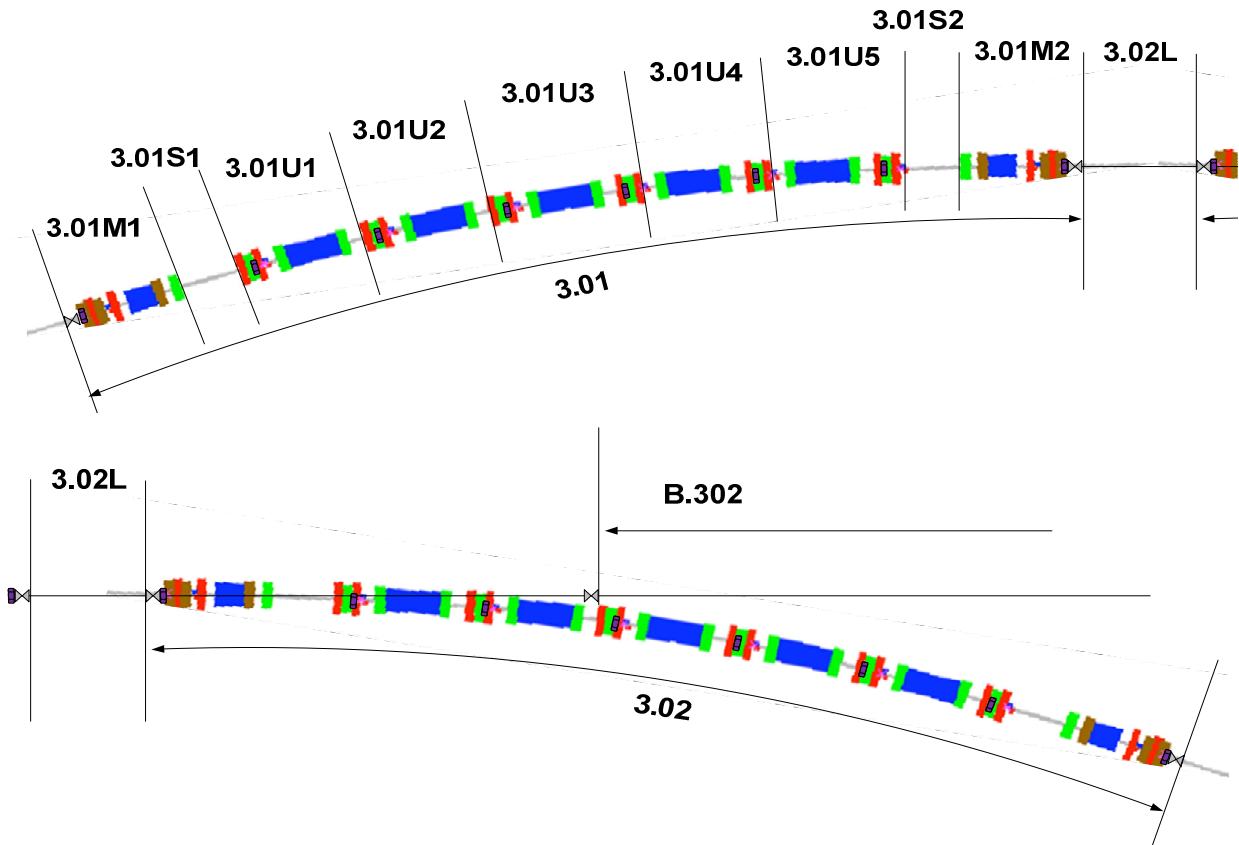

I.BC1

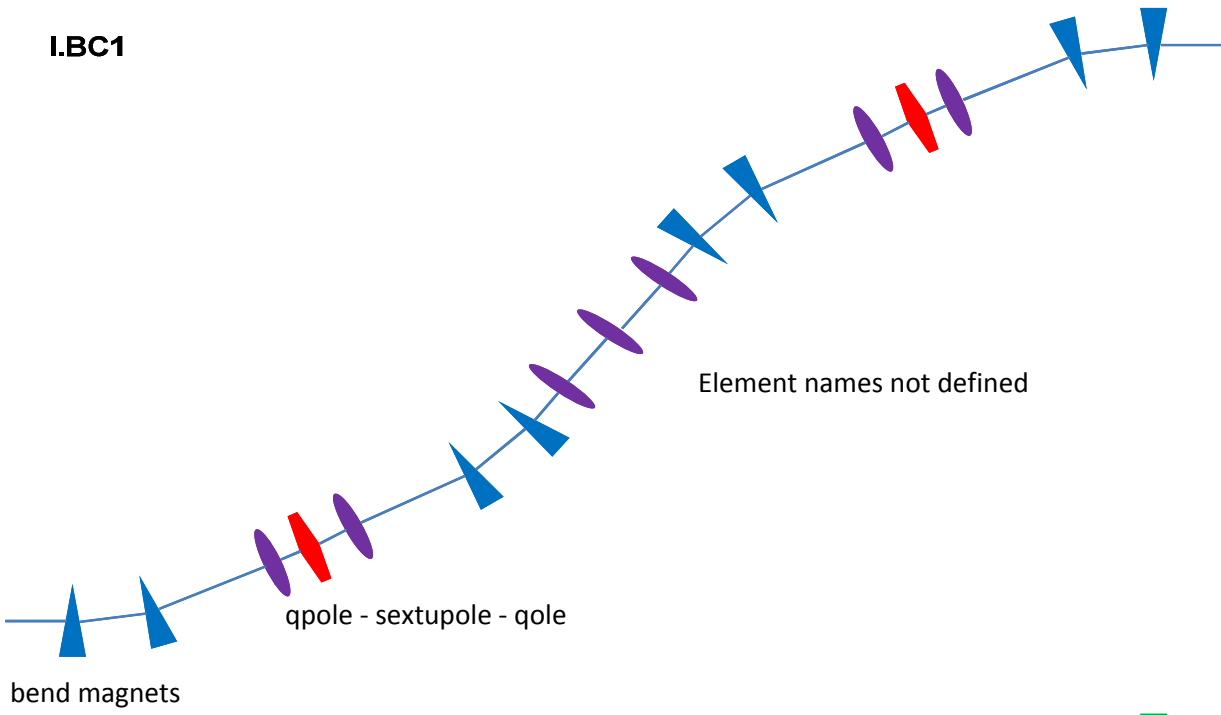

I.BC2

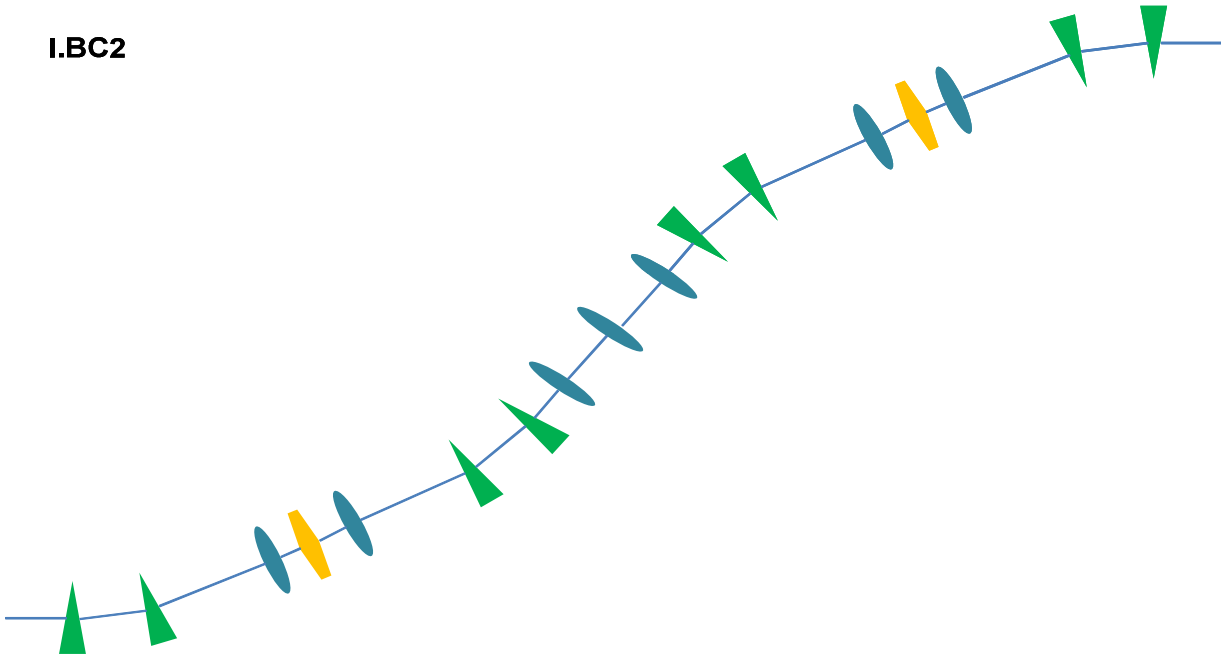

Gun, accelerator, and microwave section 00

Vacuum pumps etc is missing

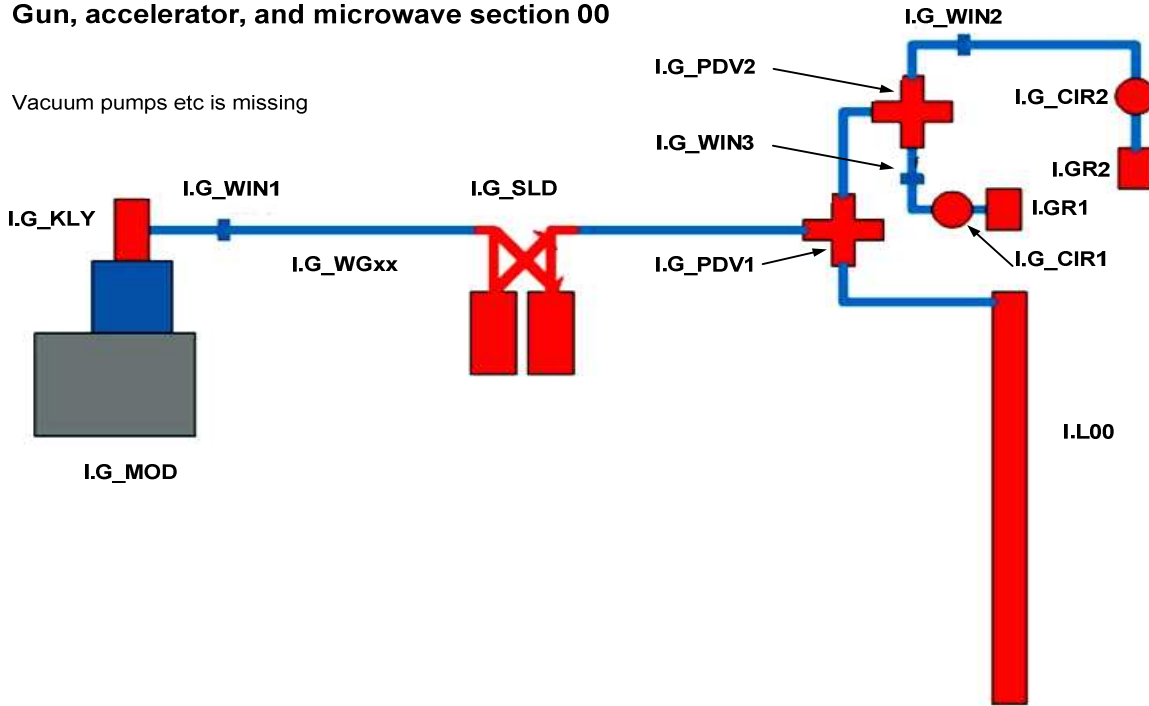

**Example:
Accelerator and microwave section 01**

Vacuum pumps etc is missing

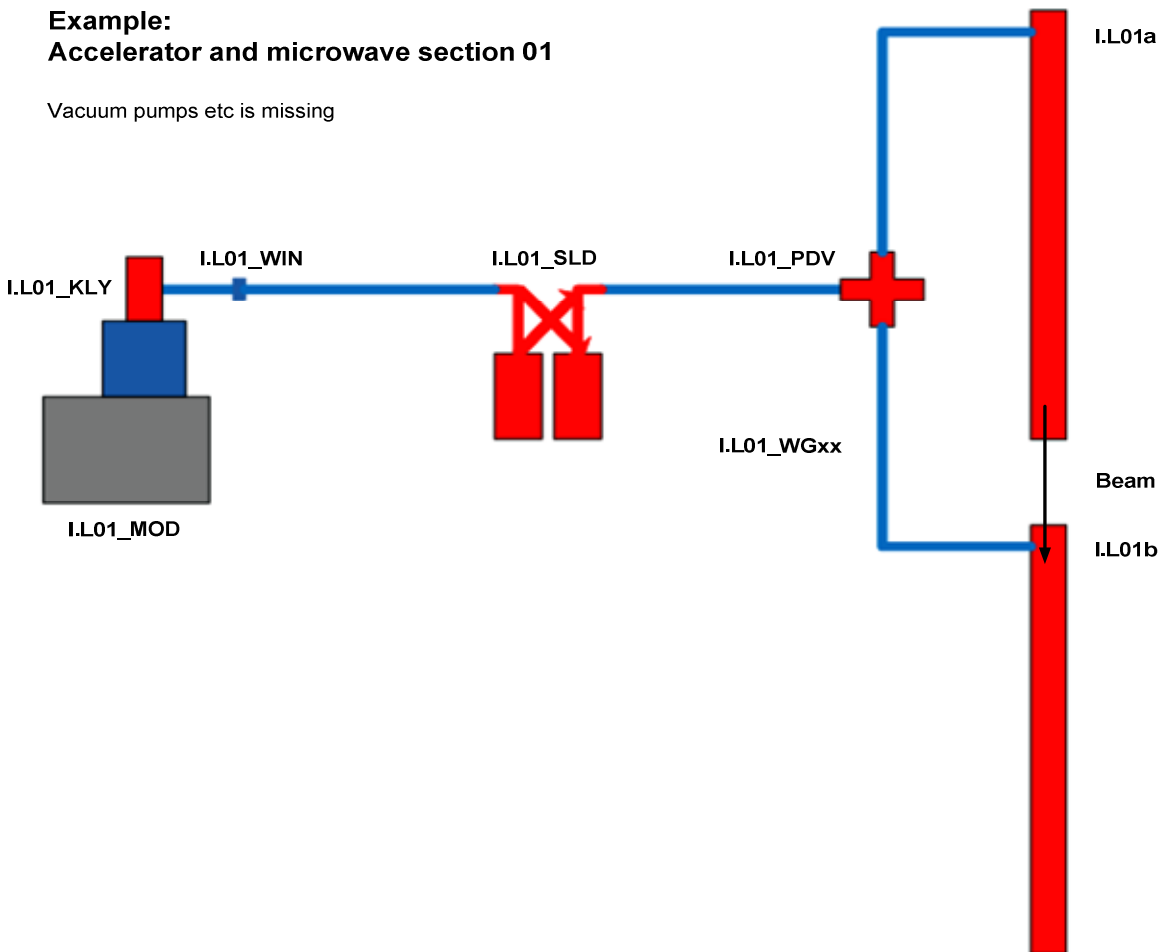

DocType		Meaning																	
DMA		Drawing Mech. Assy																	
DMP		Drawing Mech. Part																	
TMS		Text Mech. Specification																	
TES		Text El. Specification																	
TSS		Text Sys. Specification																	
TMT		Text Mech. Test Template																	
TET		Text El. Test Template																	
TMP		Text Mech. Test Protocol																	
Examples		System	What							Document									
Assembly drawing no 1 for Corrector magnet type Wide																			
in the 3GeV ring		3	-	C	O	W	-	-	-	D	M	A	0	0	1				
Part drawing no 1 of the wide BPM model		3	-	B	P	M	W	-	-	D	M	P	0	0	1				
Drawings with the same content, but in different formats (drw, pdf..) shall have the same name																			
It is the content that has the name, the file system make the difference in formats.																			
The same mechanical model used in different systems:																			
The second sextupole SXD in the first achromat, section u1, of the 3GeV ring										301U1_SXD2									
The first sextupole SXD in the second bunch compressor										IBC2_SXD1									
Each component with the same drawing shall have a serial number that might be different from the position in the system.																			
For instance there will be about 200 BPMs in the 3GeV ring.																			
Description		System	.	What							.	sub	-	Document					
First mechanical test protocol for the 3GeV BPM. serial number 3		3	.	B	P	M	-	.	S	0	0	3	-	T	M	P	0	0	1

Sorted by What								
Type	What					Name in lattice	Mech drawing	Comment
Vac	B	P	L	-	-			Stripline BPM
Vac	B	P	M	-	-			Normal BPM in 3GeV ring
Vac	B	P	M	I	-			Injection BPM in 3GeV ring
Vac	B	P	M	W	-			Wide BPM in 3GeV ring
Vac	B	S	-	-	-			Beam scraper
MW	C	I	R	-	-			Circulator
Magn	C	O	-	p	-			Correction magnet in 3GeV ring. Polarity p= X or Y
Magn	C	O	D	p	-			Correction magnet in 3GeV ring. Polarity p= X or Y For Diagnostic port
Magn	D	I	A	-	-			Low energy dipole for the injection line
Magn	D	I	B	-	-			High energy dipole for the injection line
Magn	D	I	C	-	-	VDIPS		20 degre up; bend magnet for 3GeV
Magn	D	I	D	-	-	VDIP		20 degre down; bend magnet for 3GeV
Magn	D	I	E	-	-			20 degre up; bend magnet for 1GeV
Magn	D	I	F	-	-			20 degre down; bend magnet for 1GeV
Magn	D	I	M	-	-	dipm		Matching dipole in 3GeV ring
Magn	D	I	M	C	-			Pole face strips in DIM
Magn	D	I	P	-	-	dip		Full dipole in 3GeV ring
Magn	D	I	P	C	-			Pole face strips DIP
Gen	F	G	E	-	-			Flow gauge
Gen	F	S	W	-	-			Flowswitch
ID	I	D	U	B	-			Insertion Device Undulator type B
ID	I	D	W	A	-			Insertion Device Wiggler type A
Vac	I	P	#	#	#			Sputter Ion Pump size ###I/s
Vac	I	P	C	U	#			Control unit for IP, size no #
MW	K	L	Y	-	-			Klystron
Magn	K	M	3	L	-			Long kicker magnet for the 3GeV ring
Magn	K	M	3	S	-			Short kicker magnet for the 3GeV ring
MW	M	O	D	-	-			Modulator
Magn	O	X	X	-	-	OXX	3_OX--	Octupole XX
Magn	O	X	Y	-	-	OXY	3_OX--	Octupole XY
Magn	O	Y	Y	-	-	OYY	3_OY--	Octupole YY
MW	P	D	V	-	-			Power divider
Magn	P	S	M	-	-			Pulsed sextupole magnet for injection in 3GeV ring
Magn	Q	A	-	-	-		I_QA	Qpole magnet type A: L=0.1m, ap=25mm, G=10T/m
Magn	Q	B	-	-	-		I_QB	Qpole magnet type B: L=0.2m, ap=25mm, G=10T/m
Magn	Q	C	-	-	-		I_QC	Qpole magnet type C: L=__m, ap=15mm, G=__T/m
Magn	Q	D	E	-	-	QDend	3_Q-E	Defocussing end Quadrupole
Magn	Q	F	-	-	-	QF	3_QF	Focussing Quadrupole
Magn	Q	F	E	-	-	QFend	3_Q-E	Focussing End Quadrupole
Magn	Q	F	M	-	-	QFm	3_QF	Focussing Matching Quadrupole
Magn	Q	L	A	-	-	LinQa		Quadrupole in Linac
Magn	Q	L	B	-	-	LinQb		Focussing Matching Quadrupole
RF	R	F	1	-	-			100MHz RF cavity (Driven)
RF	R	F	3	-	-			300MHz RF cavity (Landau)
MW	S	L	D	-	-			SLED cavity
Magn	S	M	1	A	-			Extraction Septum to the 1GeV ring
Magn	S	M	1	B	-			Injection Septum to the 1GeV ring

Sorted by What								
Type	What					Name in lattice	Mech drawing	Comment
Magn	S	M	3	-	-			Septum magnet for 3GeV
Magn	S	M	3	A	-	VSEPS		Extraction Septum to the 3GeV ring
Magn	S	M	3	B	-	VSEP		Injection Septum to the 3GeV ring (SM3)
Magn	S	X	D	-	-	SD	3_SXD--	Defocussing Sextupole
Magn	S	X	D	E	-	SDend	3_SXD--	Defocussing End Sextupole
Magn	S	X	F	I	-	SFi	3_SXFI-	Focussing Sextupole type i
Magn	S	X	F	M	-	SFm	3_SXF--	Focussing Sextupole type m
Magn	S	X	F	O	-	Sfo	3_SXFI-	Focussing Sextupole type o
Magn	S	X	H	-	-			High energy sextupole in injection line
Magn	S	X	L	-	-			Low energy sextupole in injection line
Gen	T	C	O	-	-			Thermocouple
Gen	T	S	W	-	-			Thermoswitch
Vac	T	U	R	-	-			Turbo pump station
Vac	V	9	M	s	-			All metal 90 degree Valve, size no s
Vac	V	C	1	-	-			Vacuum chamber type 1 in 3GeV ring
Vac	V	C	1	S	#			Stainless steel vacuum chamber in 3GeV ring
Vac	V	C	2	-	-			Vacuum chamber type 2 in 3GeV ring
Vac	V	C	2	D	-			Diagnostic version, vacuum chamber 2 in 3GeV ring
Vac	V	C	3	-	-			Vacuum chamber type 3 in 3GeV ring
Vac	V	C	5	-	-			Vacuum chamber type 5 in 3GeV ring
Vac	V	C	7	D	-			Diagnostic vacuum chamber type 7 in 3GeV ring
Vac	V	C	8	-	-			Vacuum chamber type 8 in 3GeV ring
Vac	V	C	8	A	-			Vacuum chamber upstream RF in 3GeV ring
Vac	V	C	8	B	-			Vacuum chamber downstream RF in 3GeV ring
Vac	V	C	8	D	-			Diagnostic version, vacuum chamber 8 in 3GeV ring
Vac	V	C	8	R	-			RF dummy vacuum chamber in 3GeV ring
Vac	V	C	9	-	-			Vacuum chamber type 9 in 3GeV ring
Vac	V	C	F	E	-			Vacuum chamber to front end in 3GeV ring
Vac	V	C	I	D	-			Insertion dummy vacuum chamber in 3GeV ring
Vac	V	C	K	L	-			Long kicker magnet VC with bellows in 3GeV ring
Vac	V	C	K	S	-			Short kicker magnet VC with bellows in 3GeV ring
Vac	V	G	C	-	-			Cold cathode vacuum gauge
Vac	V	G	C	C	U			Control unit for VGC
Vac	V	G	H	-	-			Hot cathode vacuum gauge
Vac	V	G	H	C	U			Control unit for VGH
Vac	V	G	M	s	-			All metal gate Valve, size no s from a separate list
Vac	V	G	O	s	-			O-ring gate Valve, size no s
Vac	V	G	P	-	-			Pirani (Thermal) vacuum gauge
Vac	V	G	P	C	U			Control unit for VGP (might be included in VGHCU)
Vac	V	G	R	s	-			RF gate Valve, size no s
Vac	V	I	S	-	-			Transport chamber for Shield in 3GeV Septum
MW	W	G	-	-	-			Wave guide
MW	W	I	N	-	-			RF-window
Gen	W	M	-	-	-			Water manifold (piping, valves etc)
						Vertical Transfer line to the 3GeV ring		
						QVFD		quadrupole

Sorted by What								
Type	What					Name in lattice	Mech drawing	Comment
						QHF		quadrupole
						QVF		quadrupole

Sorted by What								
Type	What					Name in lattice	Mech drawing	Comment
Gen	F	G	E	-	-			Flow gauge
Gen	F	S	W	-	-			Flowswitch
Gen	T	C	O	-	-			Thermocouple
Gen	T	S	W	-	-			Thermoswitch
Gen	W	M	-	-	-			Water manifold (piping, valves etc)
ID	I	D	U	B	-			Insertion Device Undulator type B
ID	I	D	W	A	-			Insertion Device Wiggler type A
Magn	C	O	-	p	-			Correction magnet in 3GeV ring. Polarity p= X or Y
Magn	C	O	D	p	-			Correction magnet in 3GeV ring. Polarity p= X or Y For Diagnostic port
Magn	D	I	A	-	-			Low energy dipole for the injection line
Magn	D	I	B	-	-			High energy dipole for the injection line
Magn	D	I	C	-	-	VDIPS		20 degre up; bend magnet for 3GeV
Magn	D	I	D	-	-	VDIP		20 degre down; bend magnet for 3GeV
Magn	D	I	E	-	-			20 degre up; bend magnet for 1GeV
Magn	D	I	F	-	-			20 degre down; bend magnet for 1GeV
Magn	D	I	M	-	-	dipm		Matching dipole in 3GeV ring
Magn	D	I	M	C	-			Pole face strips in DIM
Magn	D	I	P	-	-	dip		Full dipole in 3GeV ring
Magn	D	I	P	C	-			Pole face strips DIP
Magn	K	M	3	L	-			Long kicker magnet for the 3GeV ring
Magn	K	M	3	S	-			Short kicker magnet for the 3GeV ring
Magn	O	X	X	-	-	OXX	3_OX--	Octupole XX
Magn	O	X	Y	-	-	OXY	3_OX--	Octupole XY
Magn	O	Y	Y	-	-	OYY	3_OY--	Octupole YY
Magn	P	S	M	-	-			Pulsed sextupole magnet for injection in 3GeV ring
Magn	Q	A	-	-	-		I_QA	Qpole magnet type A: L=0.1m, ap=25mm, G=10T/m
Magn	Q	B	-	-	-		I_QB	Qpole magnet type B: L=0.2m, ap=25mm, G=10T/m
Magn	Q	C	-	-	-		I_QC	Qpole magnet type C: L=__m, ap=15mm, G=__T/m
Magn	Q	D	E	-	-	QDend	3_Q-E	Defocussing end Quadrupole
Magn	Q	F	-	-	-	QF	3_QF	Focussing Quadrupole
Magn	Q	F	E	-	-	QFend	3_Q-E	Focussing End Quadrupole
Magn	Q	F	M	-	-	QFm	3_QF	Focussing Matching Quadrupole
Magn	Q	L	A	-	-	LinQa		Quadrupole in Linac
Magn	Q	L	B	-	-	LinQb		Focussing Matching Quadrupole
Magn	S	M	1	A	-			Extraction Septum to the 1GeV ring
Magn	S	M	1	B	-			Injection Septum to the 1GeV ring
Magn	S	M	3	-	-			Septum magnet for 3GeV
Magn	S	M	3	A	-	VSEPS		Extraction Septum to the 3GeV ring
Magn	S	M	3	B	-	VSEP		Injection Septum to the 3GeV ring (SM3)
Magn	S	X	D	-	-	SD	3_SXD--	Defocussing Sextupole
Magn	S	X	D	E	-	SDend	3_SXD--	Defocussing End Sextupole
Magn	S	X	F	I	-	SFi	3_SXFI-	Focussing Sextupole type i
Magn	S	X	F	M	-	SFm	3_SXF--	Focussing Sextupole type m
Magn	S	X	F	O	-	Sfo	3_SXFI-	Focussing Sextupole type o
Magn	S	X	H	-	-			High energy sextupole in injection line
Magn	S	X	L	-	-			Low energy sextupole in injection line
MW	C	I	R	-	-			Circulator

Sorted by What								
Type	What					Name in lattice	Mech drawing	Comment
						QHF		quadrupole
						QVF		quadrupole