



Prospects of Fs XAS with Slicing Sources

Hermann A. Dürr



Hermann Dürr, Lund, 2007



Generation of Fs X-Rays: FemtoSlicing

first setup at ALS

energy modulation of electron bunch by fs laser

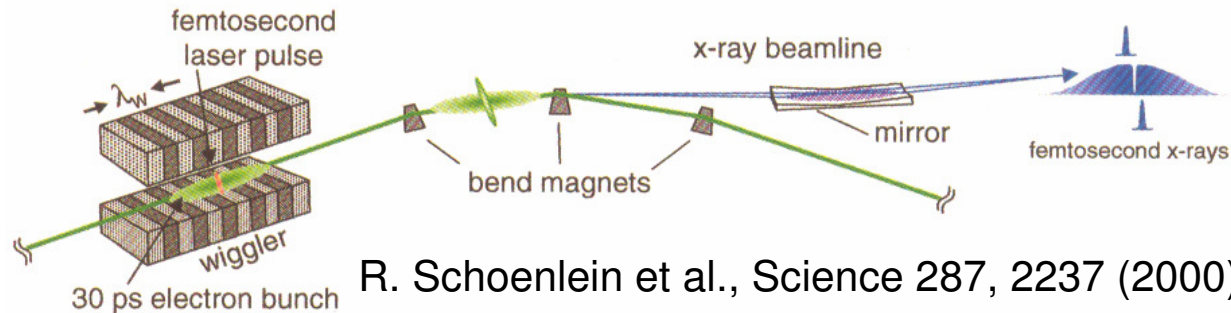

new concept at BESSY (@SLS hard x-rays)

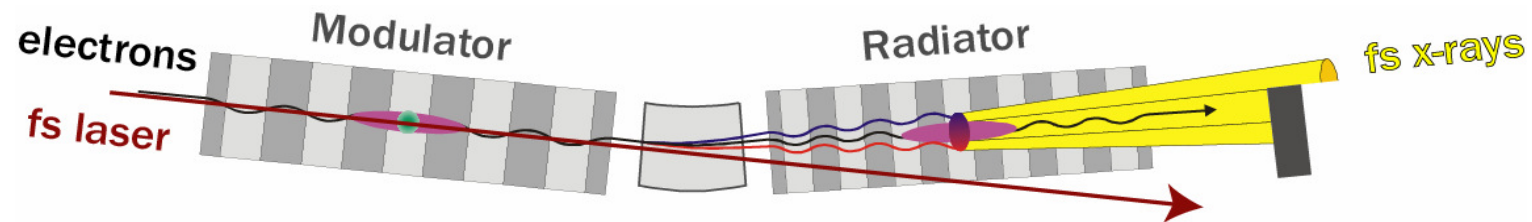

- circular and linear polarization
- x-rays generated by second undulator (“radiator”)
- angle separation for better background suppression



Generation of Fs X-Rays: FemtoSlicing

first setup at ALS

energy modula

HGHG-FEL Test Bench

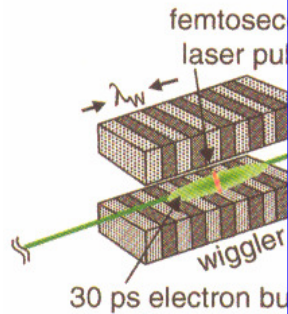

Laser electron interaction
 Synchronization
 Energy transfer
 THz-Diagnostics

new conc



Pump-probe experiments
 Synchronization
 Beam transfer
 X-ray pulse characterization

-rays

00)

ays)

fs x-rays

- circular and linear polarization
- x-rays generated by second undulator (“radiator”)
- angle separation for better background suppression

Femtosecond Energy Transfer

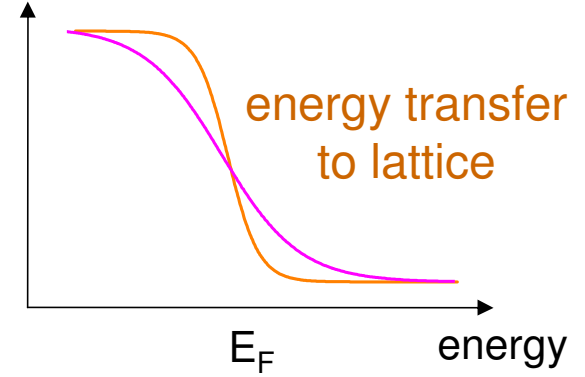
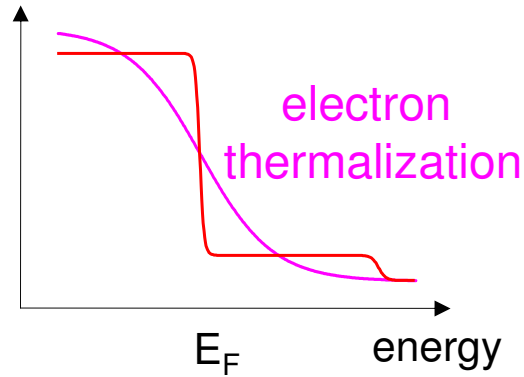
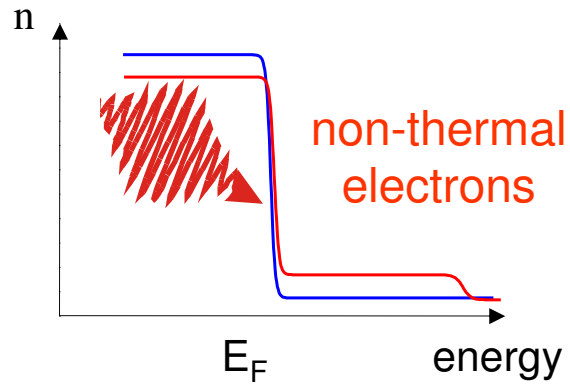

fs laser pulse

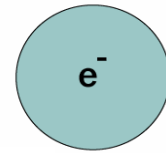

XAS: element specific electronic structure

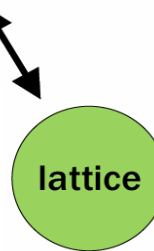

ultrafast
 - meting
 - shock waves
 - coherent phonons

Time Scales in Magnetism

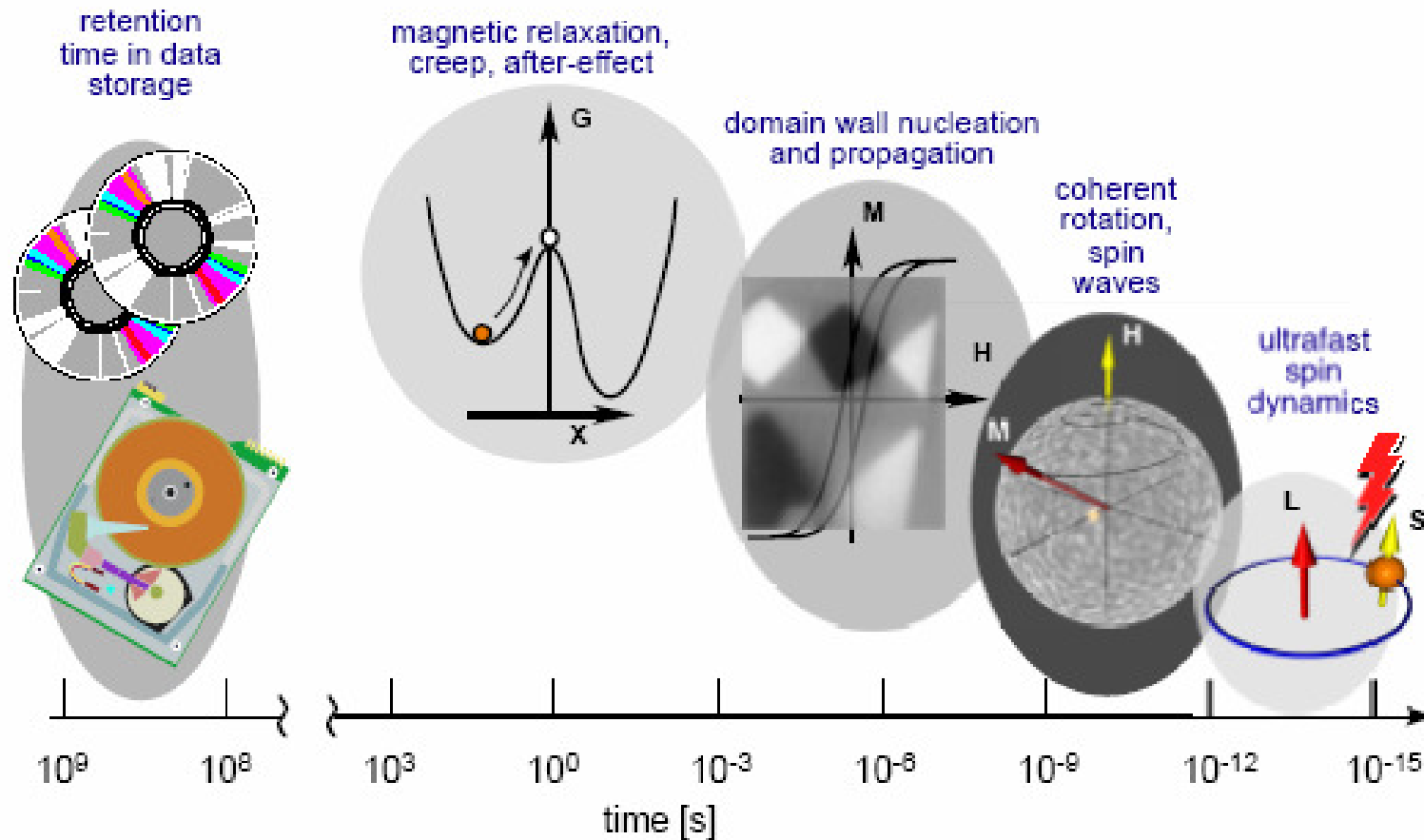

conserve total angular momentum

$$J = S_e + L_e + L(\text{lattice}) + L(\text{laser})$$

Einstein – de Haas Effect

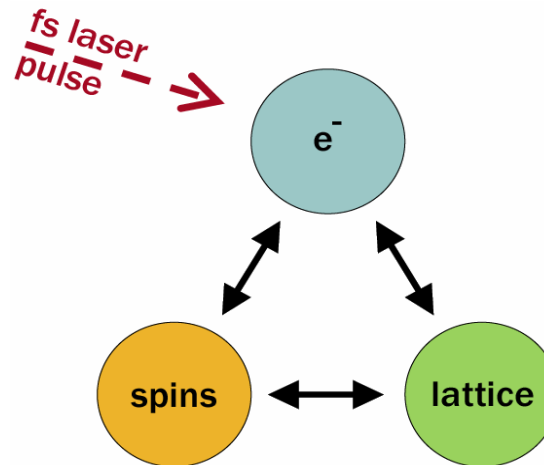
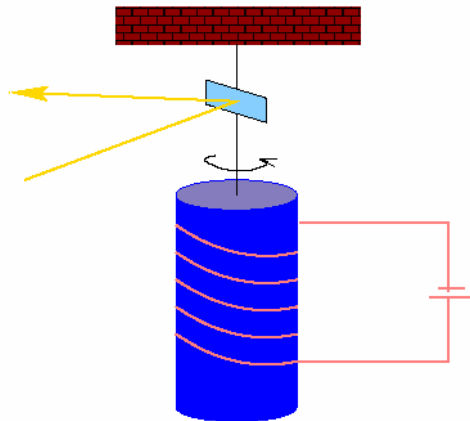

X-ray absorption spectroscopy

separation of spin and orbital angular momentum

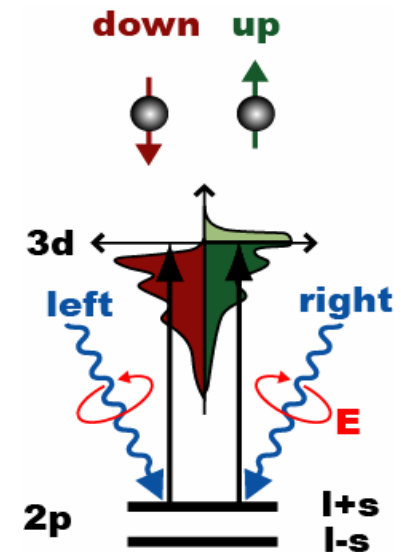

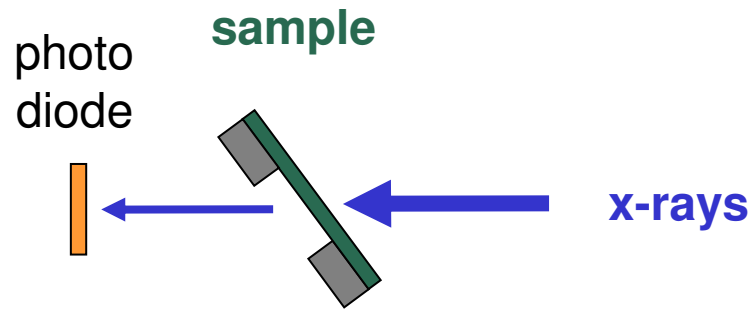

15 nm Ni film

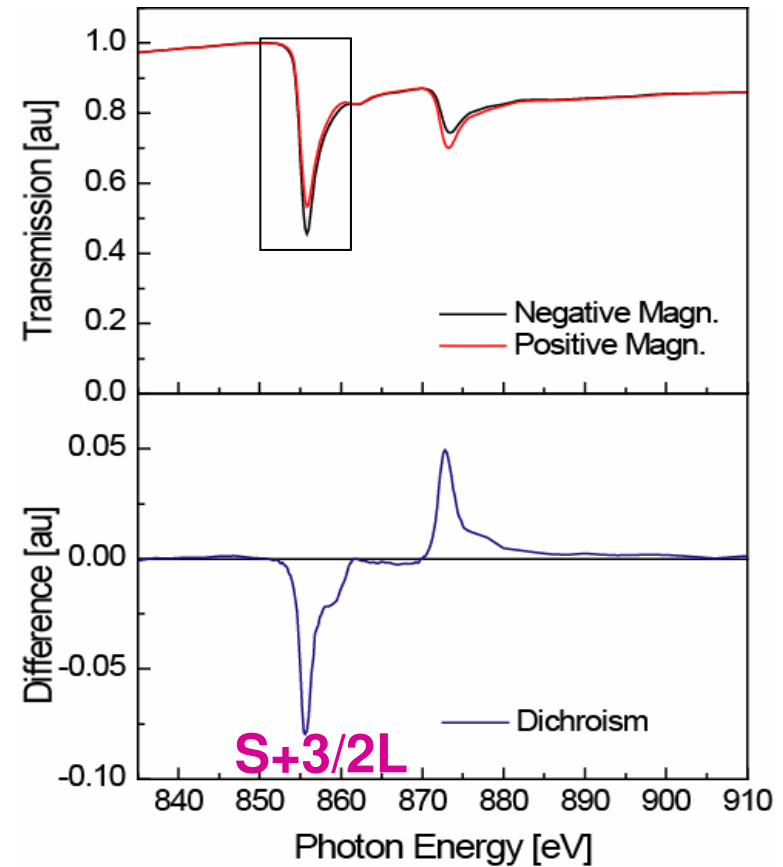

separate spin, S , and orbital, L , moments



Fs Electron & Angular Momentum Dynamics

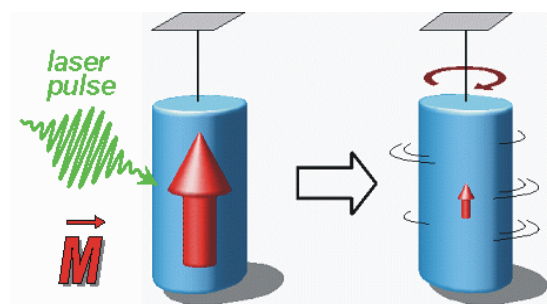
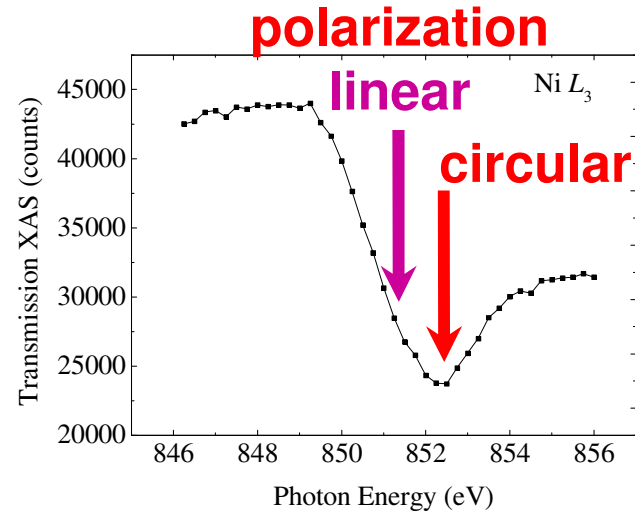

spin-lattice relaxation
120 ± 70 fs

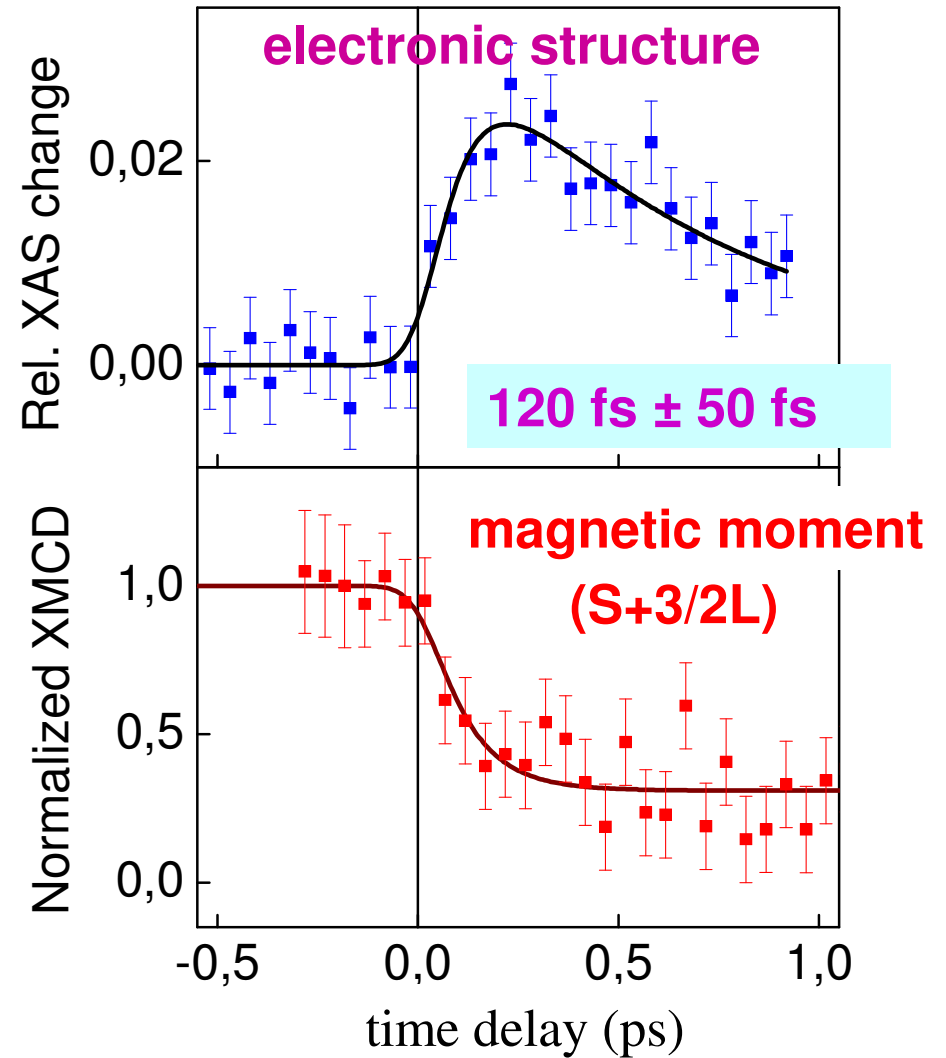

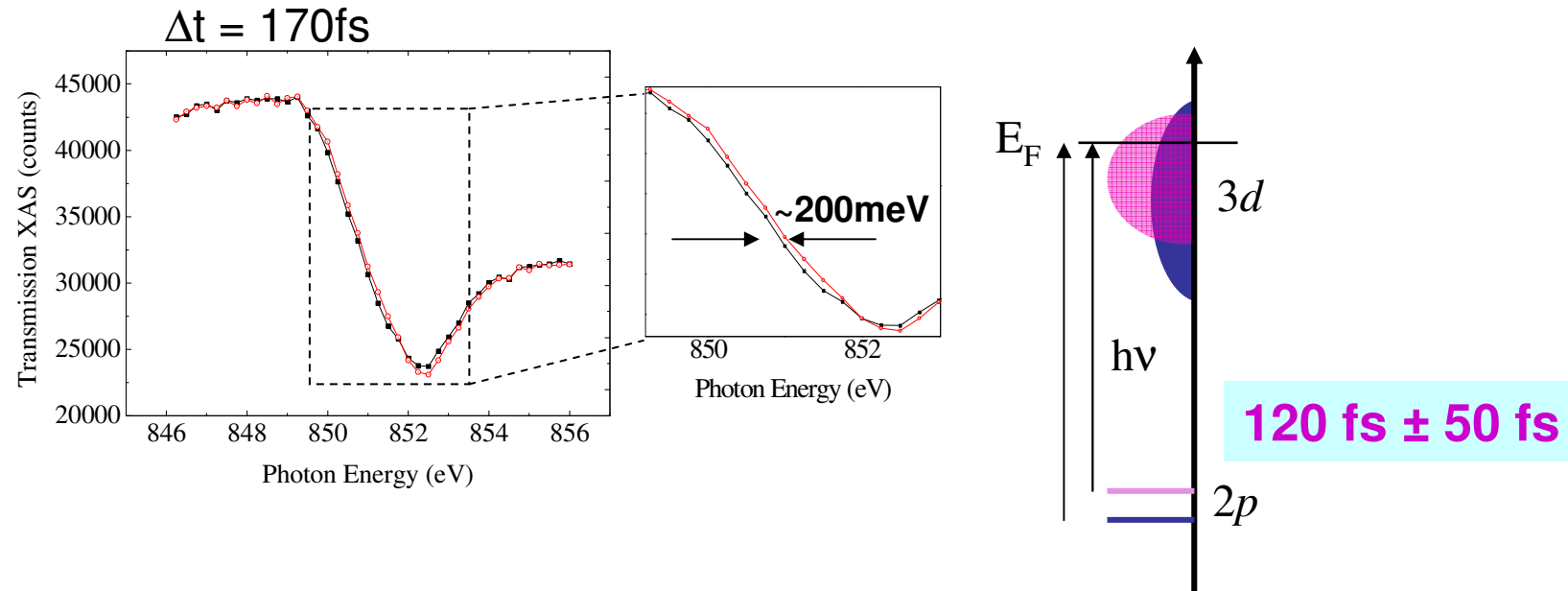

photoemission shows no
 $\sim 200\text{meV}$ shift of E_F

Rhie, Dürr, Eberhardt,
 PRL **90**, 247201 (2003);
 Appl. Phys. A, **82**, 9 (2006).

fs core level shift indicates
 valence electron localization
 due to electron-hole scattering

fs x-ray absorption spectroscopy can probe

spin-lattice relaxation

and

valence electron localization

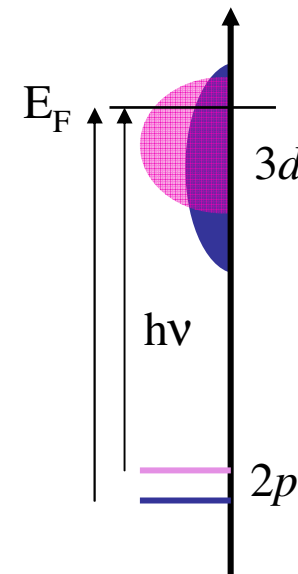
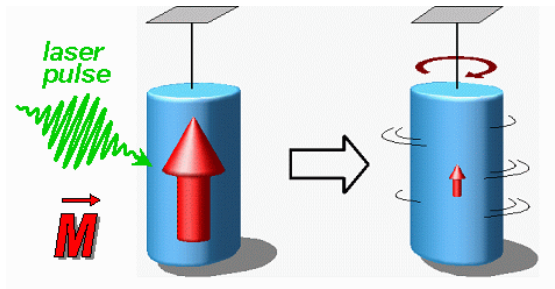

Outlook: FemtoSlicing Upgrade

increase laser repetition rate
 1kHz \rightarrow 3kHz \rightarrow >10kHz

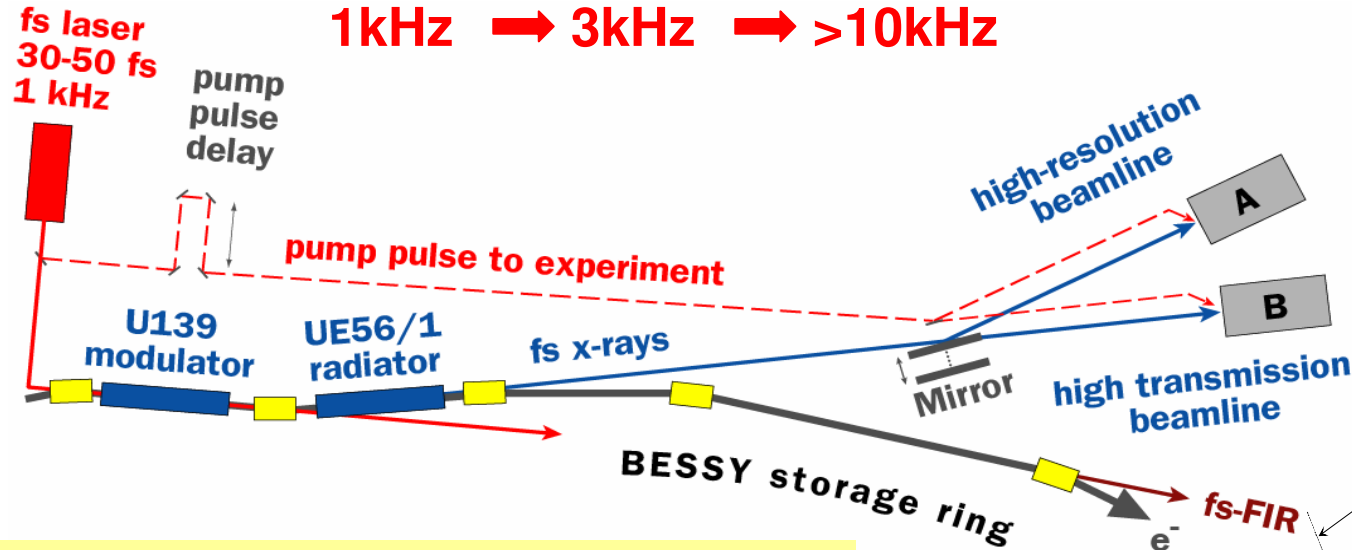

parallel detection

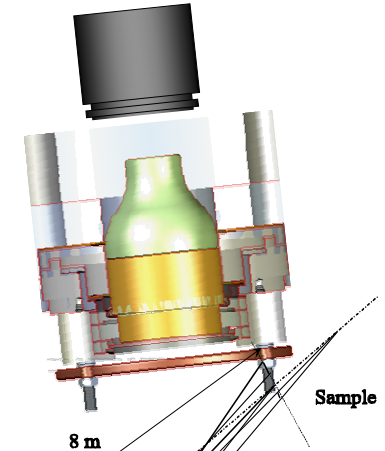

increase of photon flux
 $\sim 10^4 \text{ s}^{-1} \rightarrow > 10^7 \text{ s}^{-1}$

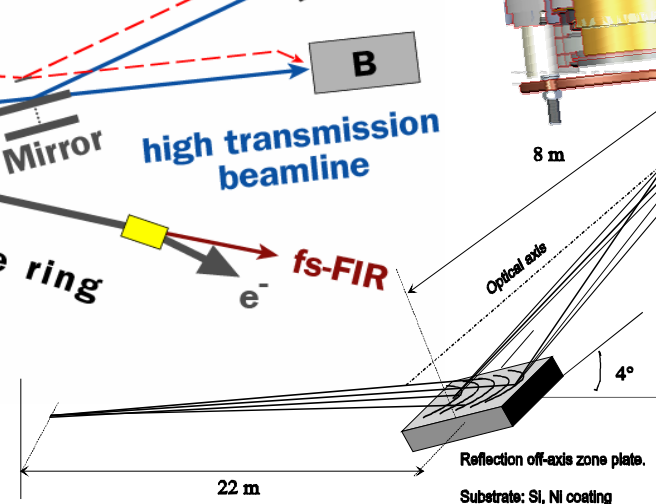

Fresnel zone plate as single optical element

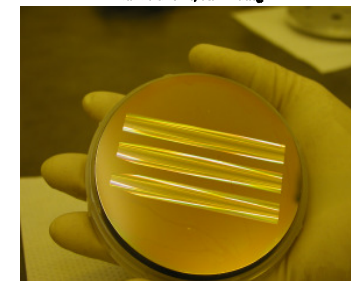

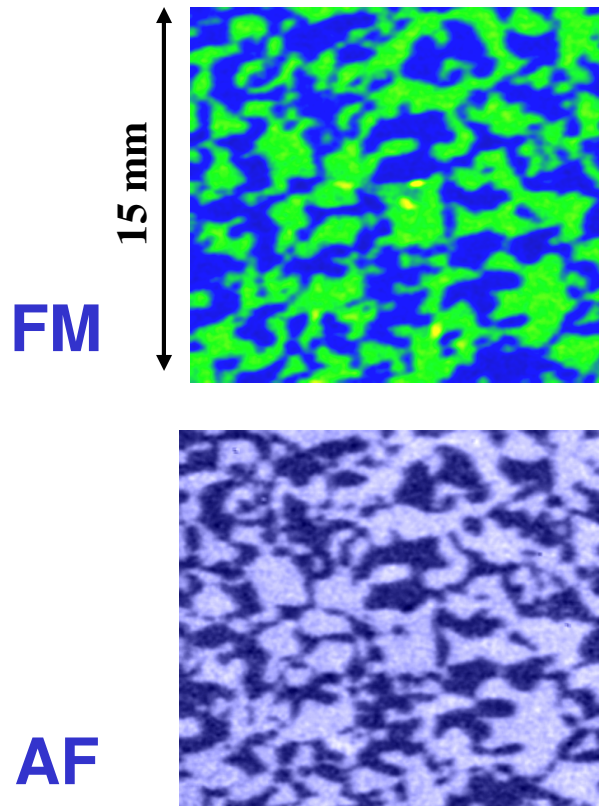

FM and AF domain imaging
A. Scholl, ALS Berkeley

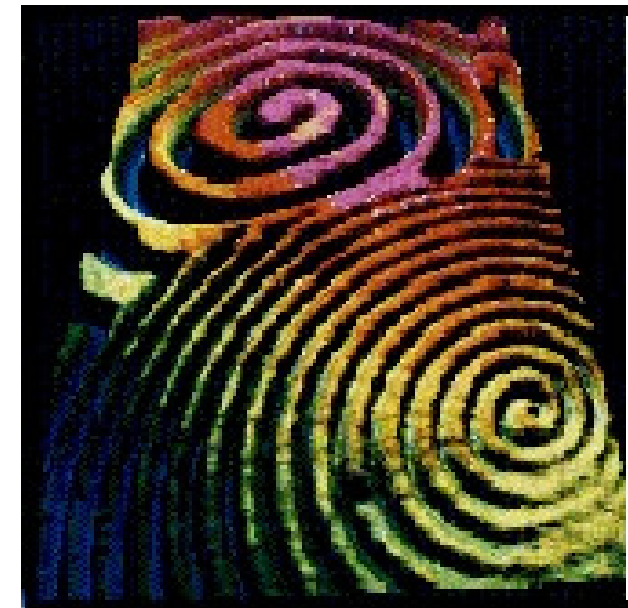
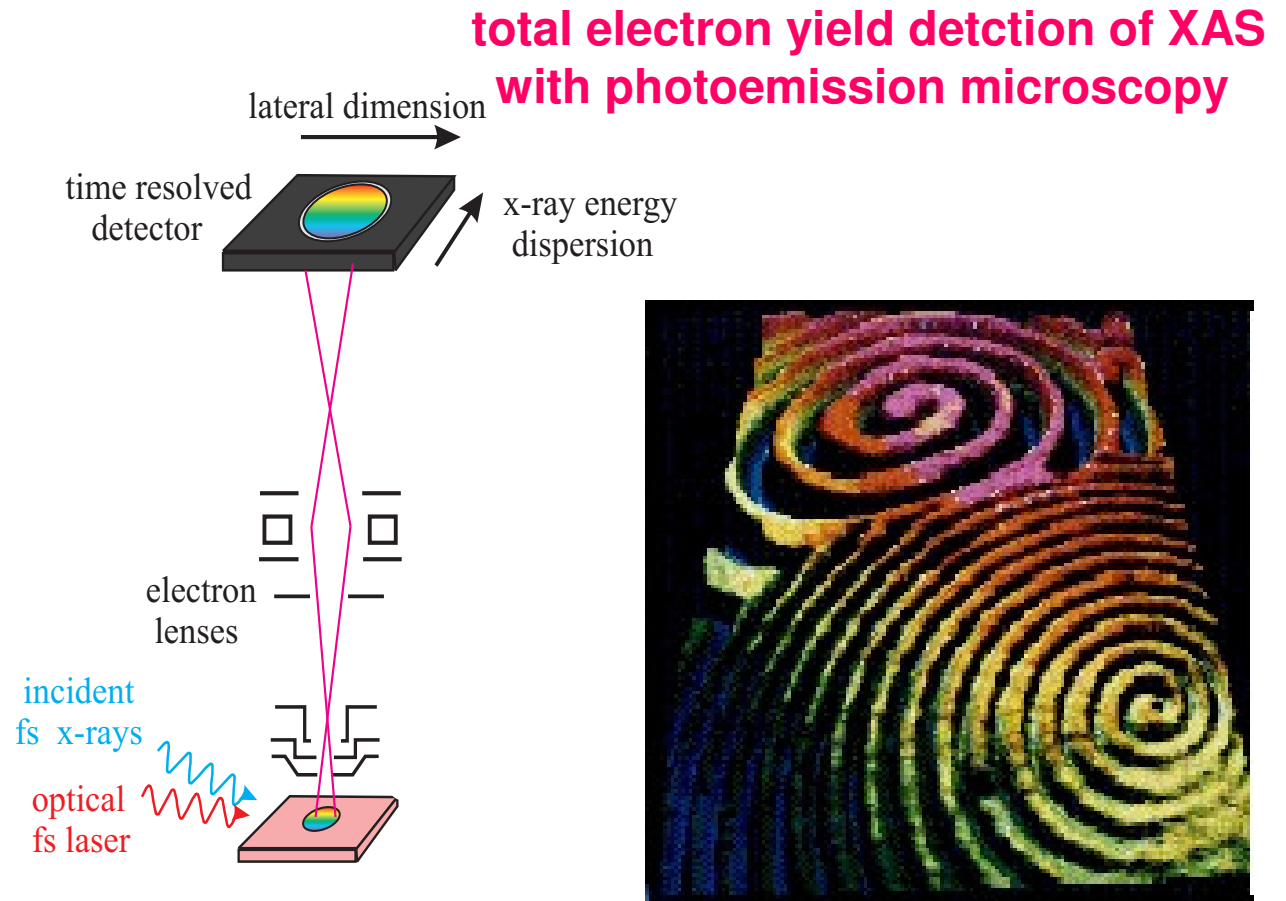

Pattern formation during a
chemical reaction
G. Ertl FHI Berlin